



# **Steadicom C1 Pro - Roaming Hub**

User Manual

V1.0

# Contents

<b>1. Product Introduction</b> .....	<b>3</b>
1.1 Key Features.....	3
1.2 Packing List.....	4
1.3 Product Overview.....	5
<b>2. Specifications</b> .....	<b>8</b>
<b>3. Product Usage</b> .....	<b>9</b>
3.1 Product Installation.....	9
3.2 Product Connection.....	11
3.3 Cascade Connection.....	14
3.4 Group Assignment.....	21
3.5 Hub Upgrade.....	23
3.6 Headset Upgrade.....	25
3.7 Hub Configuration.....	27
3.7.1 Home Page.....	27
3.7.2 Network Settings.....	28
3.7.3 Bluetooth Settings.....	28
3.7.4 Headset Deletion.....	29
3.7.5 Group Settings.....	30
3.7.6 4-Wire Settings.....	31
3.7.7 NFC Settings.....	33
3.7.8 Master/Remote Switch.....	33
3.7.9 Information.....	34
3.7.10 Placement Reference.....	34
<b>4. Web Configuration</b> .....	<b>36</b>
4.1 Logging into the Web Interface.....	36
4.2 Interface Overview.....	38

# Contents

4.3 Functions Introduction .....	39
4.3.1 Talking Mode.....	39
4.3.2 Group Assignment.....	39
4.3.3 Beltpack/Headset Deletion .....	41
4.3.4 Manual Configuration.....	41
4.3.5 One-Click Configuration .....	42
4.3.6 Role Management.....	43
4.3.7 Network Settings.....	44
4.3.8 Bluetooth and NFC Settings.....	44
4.3.9 4-Wire Settings.....	45
4.3.10 Others.....	45
<b>5. App Configuration.....</b>	<b>46</b>
5.1 Connecting to the Hub.....	46
5.2 Home Page.....	48
5.3 Functions Introduction .....	49
5.3.1 Group Assignment.....	49
5.3.2 Manual Configuration.....	50
5.3.3 One-Click Configuration .....	51
5.3.4 Beltpack/Headset Deletion .....	52
5.3.5 Role Management.....	53
5.3.6 Network Settings.....	54
5.3.7 4-Wire Settings.....	55
5.3.8 Bluetooth and NFC Settings.....	56
5.3.9 Factory Reset.....	57
5.3.10 Version Information.....	58
<b>6. Disclaimer .....</b>	<b>59</b>

## 1.1 Key Features

- The full-duplex headsets enable simultaneous communication without the need to press buttons, with a communication range of 500m (1,600ft) between the headset and the hub.
- The hub can support up to 20 headsets, is compatible with older headset models, supports 6 groups, and can be quickly configured via a mobile app or webpage.
- Supports roaming. When two hubs are cascaded via IP, headsets that move out of the coverage area of one hub automatically connect to the other hub, ensuring extendable communication.
- Delivers high-quality audio free of background noise, with a frequency response range of 100 Hz - 7 kHz, a signal-to-noise ratio greater than 55dB, and a distortion rate of less than 1%.
- Features ENC dual-mic noise cancellation technology, providing higher quality communication in noisy environments.
- Operates on the 1.9 GHz frequency band, and complies with regulations across different countries and regions.
- Boasts various ports, such as a LAN port and a 4-wire port, supports cascading between hubs, and is compatible with third-party audio devices.
- The hub supports multiple power supply methods, including V-Mount batteries, G-Mount batteries, and 12V/2A DC power.
- The hub can connect to a computer via USB to achieve UAC functionality, allowing integration with remote conferencing software.
- The hub supports multiple upgrade methods, including OTA and webpage, and the headsets can be upgraded by connecting them to the hub via USB.

# Product Introduction

## 1.2 Packing List

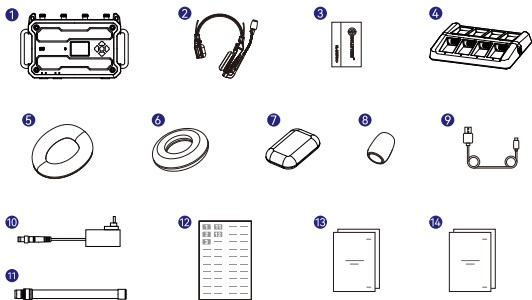

Item	10S	20S
① Hub	1	1
② Remote Headset	10	20
③ Lithium Battery	20	40
④ 8-Slot Charging Case	1	3
⑤ Over-Ear Earmuff	10	20
⑥ On-Ear Earmuff	10	20
⑦ Ear Pad	10	20
⑧ Mic Cushion	10	20
⑨ USB-A to USB-C Cable	1	1
⑩ 12V/2A Power Adapter	1	3
⑪ Antenna	4	4
⑫ Sticker	1	2
⑬ User Manual	2	2
⑭ Packing List Card & Warranty Card & Compliance Information	1	1

## 1.3 Product Overview

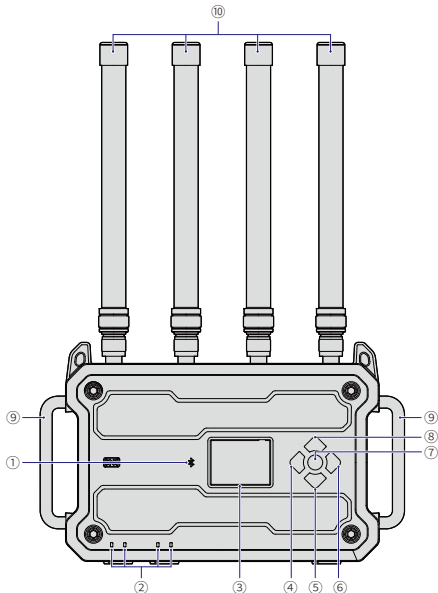

① Bluetooth Indicator

② IP Indicator

③ Display Screen

④ Left Button

⑤ Down Button

⑥ Right Button

⑦ Menu/Confirm Button

(Long press to enter menu;  
press to confirm)

⑧ Up Button

⑨ Handle

⑩ RF Antenna

## Product Introduction

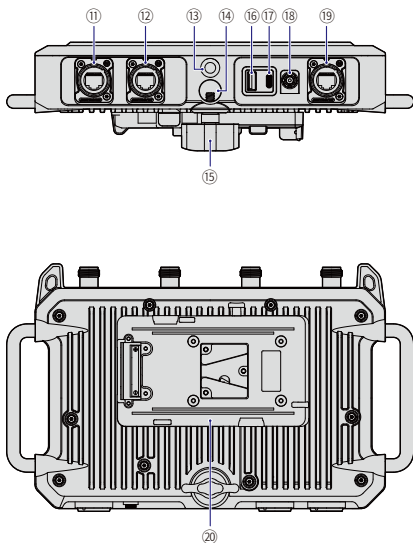

- ⑪ RJ45 Port 1
- ⑫ RJ45 Port 2
- ⑬ 3/8" Threaded Hole
- ⑭ 5/8" Threaded Hole
- ⑮ Limit Knob
- ⑯ USB-A Port (for headset pairing)
- ⑰ USB-C Port (for UAC audio)
- ⑱ DC Input
- ⑲ RJ45 Port 3 (4-wire)
- ⑳ V/G-Mount Battery Plate

# Product Introduction

## RJ45 1/2 Pinout

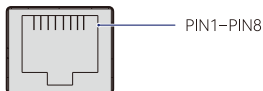

RJ45

Standard Pinout			
PIN1	Transceive Data+	PIN5	CLK 100Hz-
PIN2	Transceive Data-	PIN6	Receive Data-
PIN3	Receive Data+	PIN7	CLK GND
PIN4	CLK 100Hz+	PIN8	CLK GND

## RJ45 3 Pinout

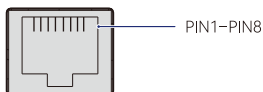

4 WIRE

Standard Pinout			
PIN1	GND	PIN5	AUDIO OUT-
PIN2	GND	PIN6	AUDIO IN-
PIN3	AUDIO IN+	PIN7	GND
PIN4	AUDIO OUT+	PIN8	GND

Crossover Pinout			
PIN1	GND	PIN5	AUDIO IN-
PIN2	GND	PIN6	AUDIO OUT-
PIN3	AUDIO OUT+	PIN7	GND
PIN4	AUDIO IN+	PIN8	GND



## Specifications

	Hub
LOS Range	1,600ft (500m)
Transmit Power	≤ 21 dBm
Bandwidth	1.728 MHz
Modulation Mode	GFSK
Frequency Response	100 Hz - 7 kHz (±3dB) @1 kHz
Receiver Sensitivity	≤ -90 dBm
SNR	> 55dB
Distortion	< 1%
Antenna Gain	4 dBi (all directions)
DC Voltage Range	7 - 30V, < 1A@12V
V/G Mount Battery Voltage Range	11 - 30V, < 1A@12V
Power Consumption	< 1A@12V
Dimensions	302mm × 181.52mm × 63.6mm
Weight	1,797.5g (63.4oz)
Temperature Range	-10 - 45°C (working) -20 - 60°C (storage)

## 3.1 Product Installation

- ① Install the antennas as shown in the diagram.

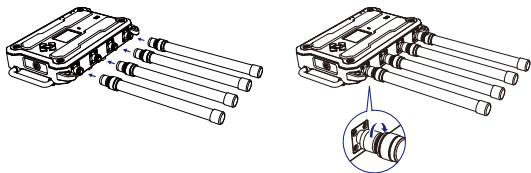

- ② Install the battery or connect to the power adapter.

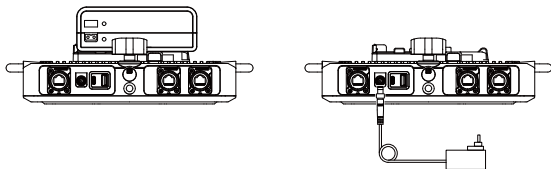

- ③ Mount the hub on a tripod and secure it.

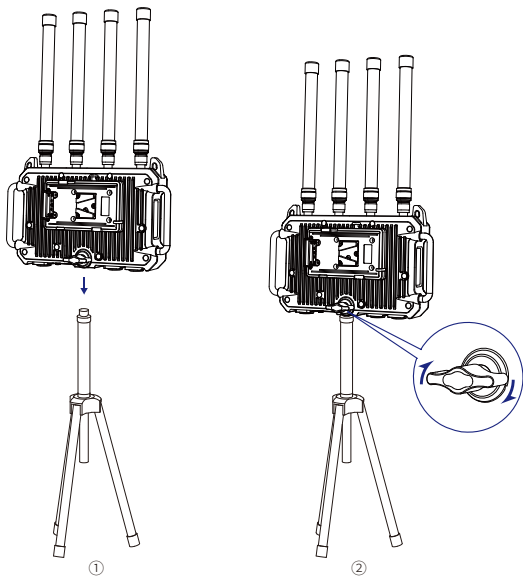

**Note:**

When setting up the hub, elevate it to approximately 1.7 meters to avoid wireless signal obstruction by people and other obstacles.

## 3.2 Product Connection

### Single Hub Connection

#### Condition One

For headsets in the Steadicom C1 Pro - Roaming Hub package, since the hub and headsets have already been paired at the factory, they can be used immediately after power-on.

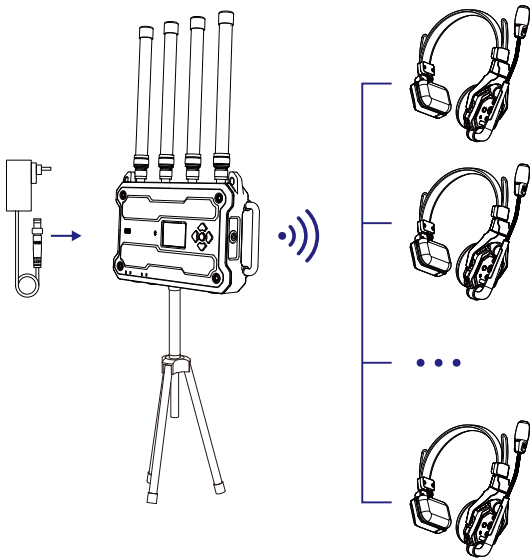

## Product Usage

### Condition Two

For previously purchased Steadicom C1 and Steadicom C1 Pro headsets, the hub and headsets need to be manually paired before use. The pairing procedures are as follows.

- ① Power on the hub and headset, and then use a USB-A to USB-C cable to connect them.

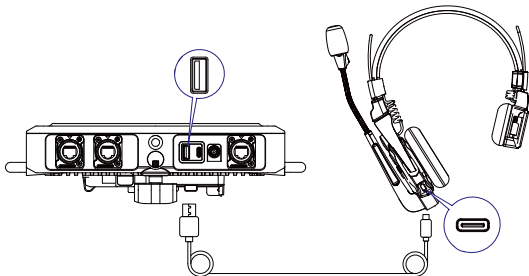

- ② A pop-up window appears, indicating a firmware version mismatch. Choose **Yes** to upgrade the headset.

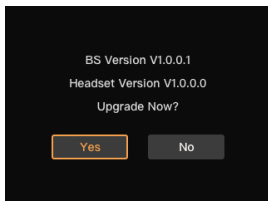

## Product Usage

- ③ After the upgrade is completed, a pop-up window appears on the hub, prompting you to assign a number to the pairing headset. Numbers in yellow are in use and hence not selectable, while numbers in gray are selectable. Select an appropriate number and choose **Confirm** to complete the pairing process.

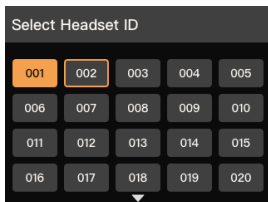

- ④ Start you work.

**Note:**

When two hubs are cascaded for roaming, only one headset can be paired at a time.

### 3.3 Cascade Connection

There are two methods to cascade hubs: IP digital signal cascading and 4-wire analog signal cascading. For IP cascading, hubs are cascaded via a standard CAT5e/CAT6e cable wired to the 568B standard, with a maximum cable length of 200m. This method allows for the expansion of headsets and roaming. For 4-wire cascading, the same type of cable is used, but the maximum cable length is 100 meters. This method only allows for the expansion of headsets.

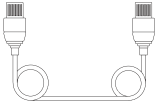
Ethernet Cable	Standard	Max Length
	CAT5e CAT6e	200m

**Note:**

When multiple hubs are used, ensure that there is a distance of at least two meters between each hub to avoid signal interference.

### Two Steadicom C1 Pro - Roaming Hubs IP Cascading

For users cascading two Steadicom C1 Pro - Roaming Hubs using the RJ45 1/2 (LAN) port, to ensure that headset-wearers can move freely between the coverage areas of the two hubs, strictly follow the steps below to guarantee reliable roaming.

- ① Before cascading the hubs, first power on all hubs and headsets as shown in the diagram, and ensure that all headsets remain on until the cascading is completed.

- Power on the headsets

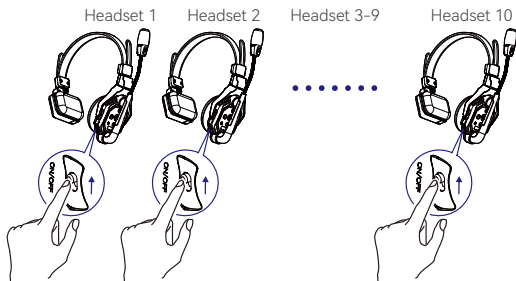

- Power on the hubs

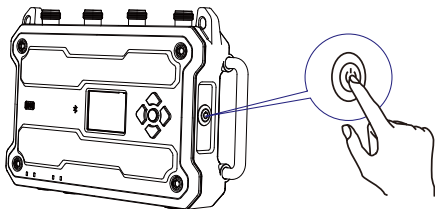



## Product Usage

- ② When the LED indicators on all headsets stop flashing and remain solid, it indicates that the headsets have successfully powered on and connected to their respective hubs. Then, you can cascade the two hubs as shown in the diagram.

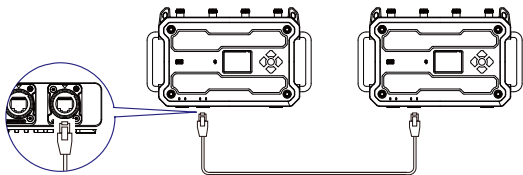

Ensure that all headsets are powered on and connected to their respective hubs before cascading the two hubs to ensure reliable roaming.

- ③ After cascading the two hubs, press and hold the menu button on each hub to access the menu interface, and select **Master/Remote Switch**. Typically, set the first hub as **Master** and the second as **Remote**. Once one hub is set as the remote device, tap **Scan** to search for the master device, and then select the desired one to complete the cascading.

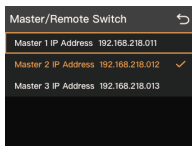
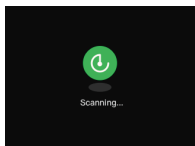
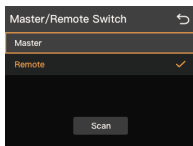

### Note:

Before setting the master and remote devices, ensure that DHCP is set to OFF on the Network Settings interface.

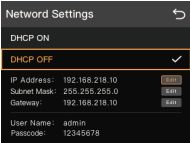
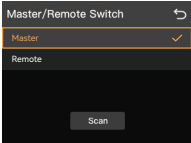
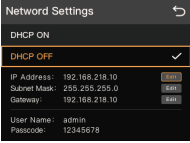
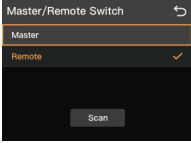
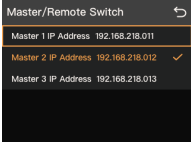
<p>Hub 1</p>	<p>Access the Network Settings interface, and set DHCP to OFF</p>	<p>Access the Master/Remote Switch interface, and select Master</p>
	 <p>The screenshot shows the 'Network Settings' screen. At the top, there is a back arrow. Below it, 'DHCP ON' is listed with a checkmark, and 'DHCP OFF' is listed with a checkmark and a checkmark icon. Below these are fields for IP Address (192.168.218.10), Subnet Mask (255.255.255.0), and Gateway (192.168.218.10), each with an 'Edit' button. At the bottom, there are fields for User Name (admin) and Passcode (12345678).</p>	 <p>The screenshot shows the 'Master/Remote Switch' screen. At the top, there is a back arrow. Below it, 'Master' is selected with a checkmark and a checkmark icon. Below it, 'Remote' is listed. At the bottom, there is a 'Scan' button.</p>
<p>Hub 2</p>	<p>Access the Network Settings interface, and set DHCP to OFF</p>	<p>Access the Master/Remote Switch interface, and select Remote</p>
	 <p>The screenshot shows the 'Network Settings' screen. At the top, there is a back arrow. Below it, 'DHCP ON' is selected with a checkmark and a checkmark icon. Below it, 'DHCP OFF' is listed. Below these are fields for IP Address (192.168.218.10), Subnet Mask (255.255.255.0), and Gateway (192.168.218.10), each with an 'Edit' button. At the bottom, there are fields for User Name (admin) and Passcode (12345678).</p>	 <p>The screenshot shows the 'Master/Remote Switch' screen. At the top, there is a back arrow. Below it, 'Master' is listed, and 'Remote' is selected with a checkmark and a checkmark icon. At the bottom, there is a 'Scan' button.</p>
	<p>Tap <b>Scan</b> to search for the master device and then select the desired one based on its IP address</p>	 <p>The screenshot shows the 'Master/Remote Switch' screen. At the top, there is a back arrow. Below it, three master devices are listed: 'Master 1 IP Address 192.168.218.011', 'Master 2 IP Address 192.168.218.012' (which is selected with a checkmark and a checkmark icon), and 'Master 3 IP Address 192.168.218.013'.</p>

## Two Steadicom C1 Pro - Roaming Hubs 4-Wire Cascading

For users cascading two Steadicom C1 Pro - Roaming Hubs using the RJ45 3 (4-wire) port, after connecting the two hubs via an Ethernet cable, press and hold the menu button on each hub and select **4-Wire Settings > Pinout Switch**. Typically, set the first hub to **Standard** and the second to **Crossover**.

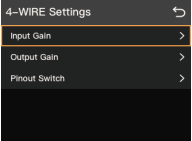
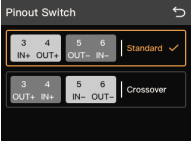
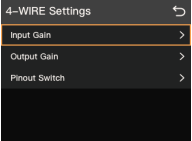
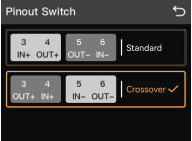
Hub 1	Select <b>4-Wire Settings &gt; Pinout Switch</b>	Choose <b>Standard</b>
		
Hub 2	Select <b>4-Wire Settings &gt; Pinout Switch</b>	Choose <b>Crossover</b>
		

## Product Usage

### Cascading between Steadicom C1 Pro - Roaming Hub and other Hubs

Different hubs can only be cascaded through 4-wire cascading, which only allows for the expansion of headsets.

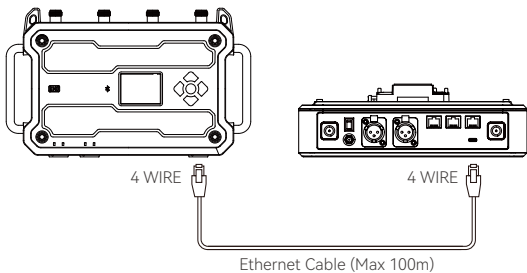

# Product Usage

## Three Hubs Cascading

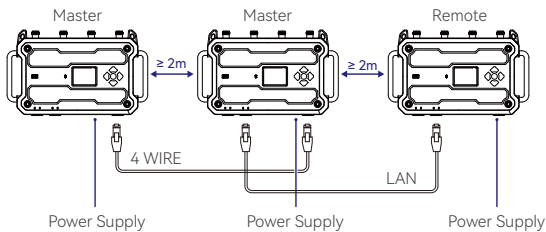

## Four Hubs Cascading

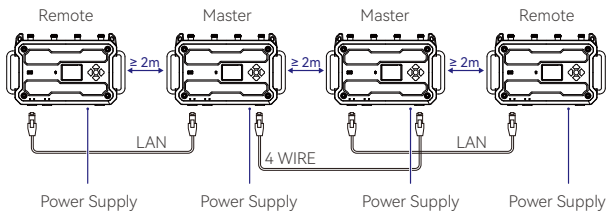

## 3.4 Group Assignment

The hub supports 6-group communication and role assignment. You can assign a specific type of role to each headset and configure the parameters for each type through the hub, webpage, or app, obviating the need to manually configure parameters for each headset. The procedures are as follows.

① Press and hold the menu button on the hub to access the Menu interface.

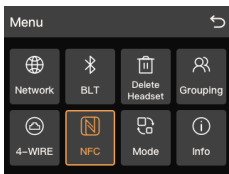

② Select **Group Settings** > **Custom** to customize the number for each type of role.

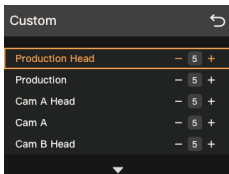
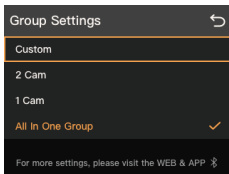

## Product Usage

- ③ The hub offers a total of 10 preset roles: Production (head/member), Cam A (cameraman group A head/member), Cam B (cameraman group B head/member), Lighting (head/member), and Grip (equipment team head/member). Each role's group and corresponding button (A/B) are detailed in the table below.

Role	Group 1	Group 2	Group 3	Group 4	Group 5	Group 6
Production (head)	A					
Production (member)	A					
Cam A (head)	A	B				
Cam A (member)		B				
Cam B (head)	A		B			
Cam B (member)			B			
Lighting (head)	A			B		
Lighting (member)				B		
Grip (head)	A				B	
Grip (member)					B	

- ④ Adjust the number for each type of role based on your actual needs, and select **Auto-Gen** to save and apply the configuration to the headsets. For example, If you set the number for Production to 5, headsets 1-5 will be assigned to Production. If you set the number for Cam A to 4, headsets 6-9 will be assigned to Cam A, and so forth.
- ⑤ Distribute the headsets to the corresponding personnel and start work.

## 3.5 Hub Upgrade

Note: You can obtain the firmware upgrade file from Eagleshero's official website or by contacting Eagleshero online technical engineers.

### Upgrade through Webpage

- ① Use a standard RJ45 Ethernet cable to connect the hub to your computer.

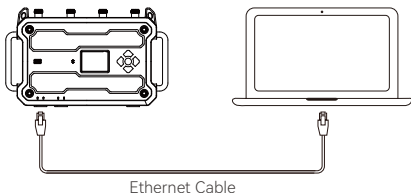

- ② Set your computer's IPv4 information to be on the same subnet as the hub, open the default browser, and enter the hub's IP address to navigate to the login page.

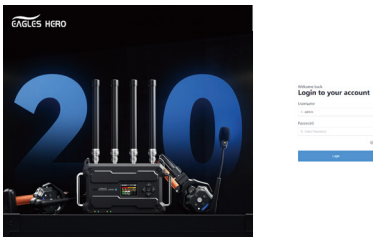

- ③ Enter the default username admin and password 12345678 or your customusername and password to log in, click **Other > Settings** to jump to the upgrade page, upload the firmware file, and click **Upgrade** to initiate the upgrade process.



## Upgrade through OTA

- ① Press and hold the menu button to access the menu interface, select **Network** and set DHCP to **ON**.

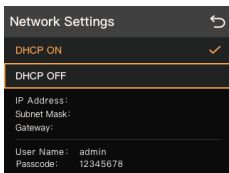

- ② Use a standard RJ45 Ethernet cable to connect the hub to a router or switch that is already connected to the Internet.
- ③ Press and hold the menu button to access the menu interface, select **Info** > **Firmware Upgrade** to start the upgrade process.

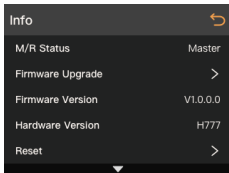

### 3.6 Headset Upgrade

#### Upgrade through Hub

- ① Power on the hub and headset, and use a USB-A to USB-C cable to connect them.

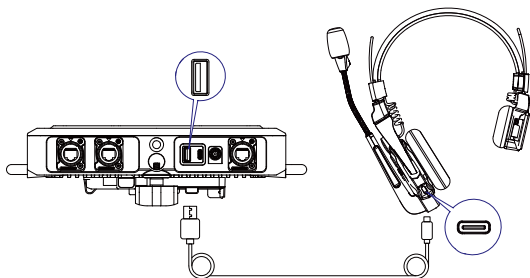

- ② A pop-up window appears on the hub, indicating a firmware version mismatch. Tap **Yes** to start the upgrade process.

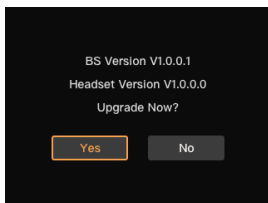

## Product Usage

### Upgrade through PC

- ① Power on the headset and open the PC software, which can be downloaded from the official website or other official sources. Connect the headset to the PC using a USB-A to USB-C cable.

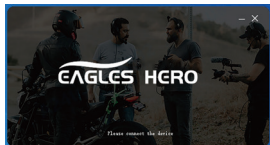
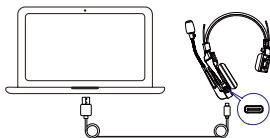

- ② Once connected, the PC software will automatically detect the headset and display the current firmware version and the available upgrade version. Click **Yes** to start the upgrade process.

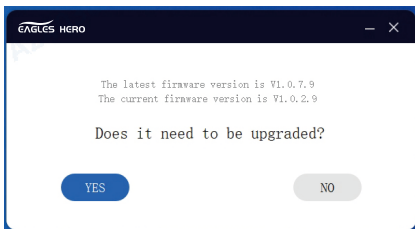

**Note:**

The PC software supports multiple instances, allowing you to upgrade multiple headsets simultaneously.

## 3.7 Hub Configuration

### 3.7.1 Home Page

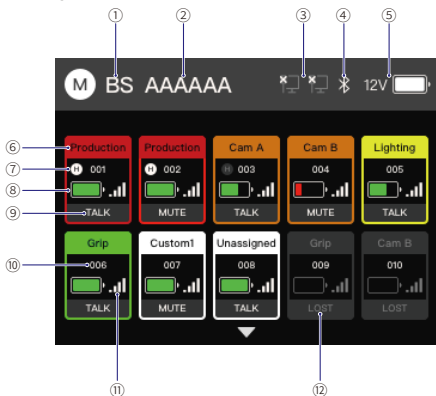

- ① Hub ID
- ② Hub Name
- ③ Hub Connection Status (PC connection/IP connection)
- ④ Bluetooth Status (white: on; gray: off)
- ⑤ Power Voltage and Battery Level
- ⑥ Headset Role
- ⑦ Head Indicator
- ⑧ Headset Battery Level
- ⑨ Headset Talk/Mute Status
- ⑩ Headset Name
- ⑪ Headset Signal Strength
- ⑫ Unconnected Headset

Press and hold the menu button for 3s to access the Menu interface.

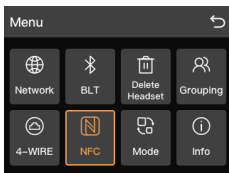

## 3.7.2 Network Settings

Select **Network** to access the Network Settings interface, where you can turn on or off DHCP. When DHCP is off, you can modify the IP address, subnet mask, and gateway information. You can also view the username and password for webpage login on this interface.

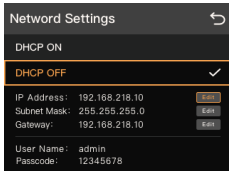

## 3.7.3 Bluetooth Settings

Select **BLT** to access the Bluetooth Settings interface, where you can view the Bluetooth name and connection status.

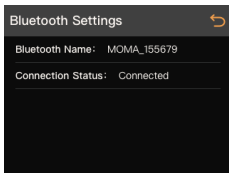

Bluetooth Status Indicator:

Blue: standby; Yellow: connected

**Note:**

A hub can be connected to only one Bluetooth device (e.g., smartphone) at a time.

## 3.7.4 Headset Deletion

Select **Delete headsets** to access the Headset Deletion interface.

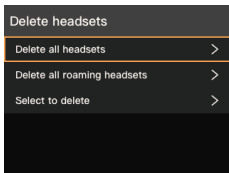

- ① Select **Delete all headsets** to delete all headsets, including the roaming headsets. After deletion, you will need to re-pair the headsets to work normally.
- ② Select **Delete all roaming headsets** to delete only the roaming headsets. After deletion, the roaming headsets will no longer be functional while other headsets will continue to function normally.
- ③ Click **Select to delete** to access the headset list interface, where you can select and delete any headsets from the list. After deletion, the corresponding headsets will no longer be functional, but the remaining headsets will continue to function normally.

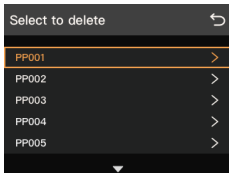

# Product Usage

## 3.7.5 Group Settings

Select **Grouping** to access the Group Settings interface.

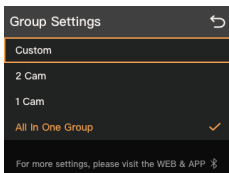

- ① Choose **Customization** to customize the number for each type of role. For more information, refer to 3.4.
- ② Choose **2 Cam** if you need to assign cameramen to two separate groups. If the default role assignments as shown in the diagram below meet your requirements, tap **Apply**.

Role	Qty	No	Group 1	Group 2	Group 3	Group 4	Group 5	Group 6
Production (head)	3	1-3	A					
Production (member)	2	4-5	A					
Cam A (head)	2	6-7	A	B				
Cam A (member)	2	8-9		B				
Cam B (head)	2	10-11	A		B			
Cam B (member)	2	12-13			B			
Lighting (head)	1	14	A			B		
Lighting (member)	2	15-16				B		
Grip (head)	2	17-18	A				B	
Grip (member)	2	19-20					B	

## Product Usage

- ③ Choose **1 Cam** if you need to assign all cameramen in one group. If the default role assignments as shown in the diagram below meet your requirements, tap **Apply**.

Role	Qty	No	Group 1	Group 2	Group 3	Group 4	Group 5	Group 6
Production (head)	3	1-3	A					
Production (member)	2	4-5	A					
Cam A (head)	2	6-7	A	B				
Cam A (member)	4	8-11		B				
Lighting (head)	2	12-13	A			B		
Lighting (member)	2	14-15				B		
Lighting (member)	2	16-17	A				B	
Grip (member)	3	18-20					B	

- ④ Choose **All In One Group** if you need all currently connected devices, including headsets, 4-wire device, and UAC device, to be in one group. All devices in this group can communicate with each other.

### 3.7.6 4-Wire Settings

Select **4-Wire** to access the 4-Wire Settings interface.

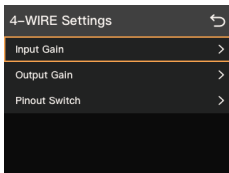



- ① Select **Input Gain** to adjust the input gain based on your needs.

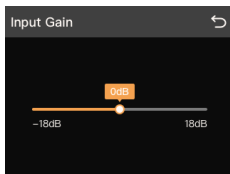

- ② Select **Output Gain** to adjust the output gain based on your needs.

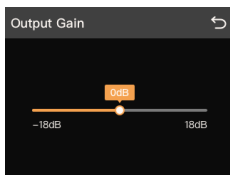

- ③ Select **Pinout Switch** to set pinout to **Standard** or **Crossover** based on your needs.

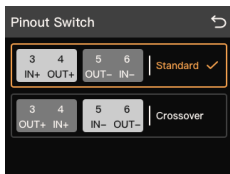

### 3.7.7 NFC Settings

Select **NFC** to access the NFC interface, where you can turn on or off the NFC functionality.

**Note:**

If NFC is set to OFF, the headset can only be paired with the hub via a wired connection. The Steadicom C1 or C1 Pro headset does not support the NFC functionality and can only be paired via a wired connection.

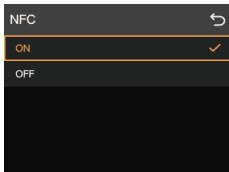

### 3.7.8 Master/Remote Switch

Select **M/R Mode** to access the Master/Remote Switch interface, where you can set the hub as either the master device or the remote device.

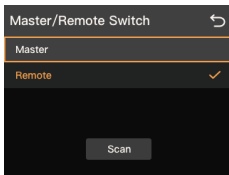

**Note:**

When only one hub is used, it defaults to the Master device. If the hub is set to Remote, it will not function properly.

## 3.7.9 Information

Select **Info** to access the Information interface, where you can view hub information, switch the language, reset the hub to factory settings, and upgrade the firmware.

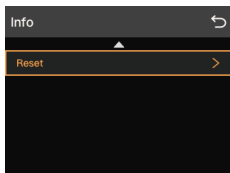
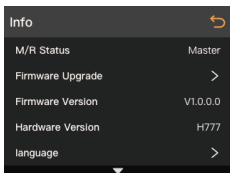

## 3.7.10 Placement Reference

Press and hold the Down button on the hub to access the interface, where you can view the optimal location for the hub. Given the RSSI (Received Signal Strength Indication) and LQ (Link Quality) values of each connected headset, the boundary of the hub's signal coverage and the signal quality in key areas are determined. It is recommended that the RSSI value of the farthest headset is greater than or equal to 35 and the LQ value is greater than or equal to 80 to achieve optimal communication experience.

The screenshot shows the Placement Reference interface with a grid of headset IDs and their RSSI and LQ values.

PP	001	002	003	004	005
RSSI	/	/	/	/	/
LQ	/	/	/	/	/
PP	006	007	008	009	010
RSSI	/	/	/	/	/
LQ	/	/	/	/	/

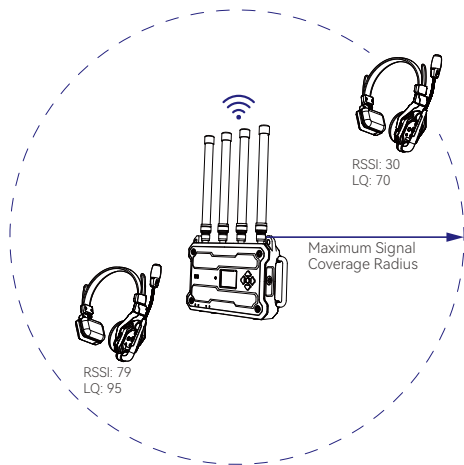

**Note:**

RSSI and LQ values are affected by the actual wireless environment and should be used only as a reference while setting up the hub.

# Web Configuration

## 4.1 Logging into the Web Interface

Power on the hub and connect one end of an Ethernet cable to the RJ45 (LAN) port on the hub and the other end to the computer's network port. Set the computer's network segment to the same as the hub. Open a browser on the computer and enter the following IP address.

Master device: 192.168.218.10

Remote device: 192.168.218.11

On the web interface, you can upgrade the hub, group the headsets, and configure headset status.

## 4 Connecting the Hub and Computer

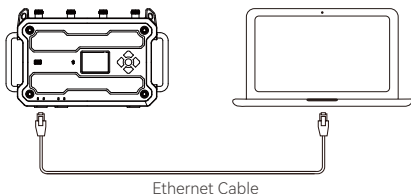

Power on the hub and connect one end of an Ethernet cable to the RJ45 (LAN) port on the hub and the other end to the computer's network port.

## Logging into the Webpage

- Press and hold the menu button to access the menu interface, select **Network** to view the IP address, login name, and password.

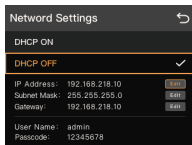

## Web Configuration

- ② Set the computer's IP address to 192.168.218.XXX. The hub's default IP address is 192.168.218.10 and subnet mask 255.255.255.0.

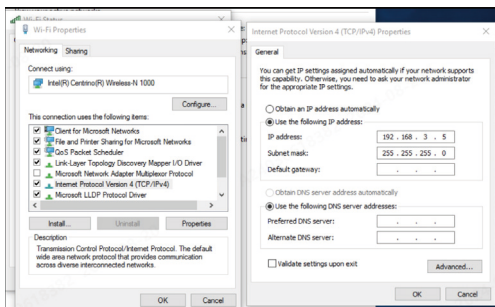

- ③ Open a browser on the computer and enter the IP address to navigate to the login interface. Enter the username and password to log in (default username: admin; password: 12345678).



## 4.2 Interface Overview

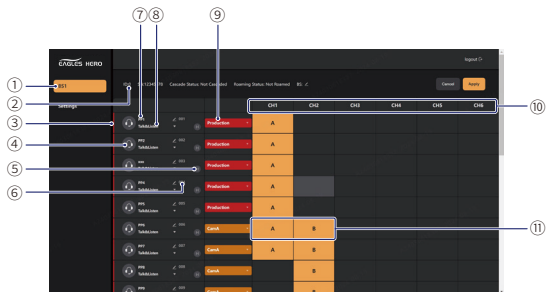

- ① Hub Name
- ② Hub Information
- ③ Device Status (green: connected; gray: disconnected)
- ④ Device Type
- ⑤ Head Indicator
- ⑥ Device ID
- ⑦ Device Name
- ⑧ Device Talking Mode
- ⑨ Device Role
- ⑩ Available Groups
- ⑪ Assigned Group for Button A/B

## 4.3 Functions Introduction

### 4.3.1 Talking Mode

Talking Mode	Functions	Note
Talk & Listen	<b>Single press:</b> Users can access or exit the group. When in the group, users can listen and talk. After exiting the group, users cannot listen and talk. <b>Long press:</b> Invalid operation.	Default status
Talk & Force Listen	<b>No operation:</b> Users can listen, but cannot talk. <b>Single press:</b> Turn the microphone on or off. <b>Long press:</b> Invalid operation.	
PTT & Force Listen	<b>No operation:</b> Users can listen, but cannot talk. <b>Single press:</b> Invalid operation. <b>Long press:</b> Press and hold to turn the microphone on, release to turn the microphone off.	PTT=Push to Talk

### 4.3.2 Group Assignment

Based on the headset and the group you want to assign it to, select a gray square on the right side. After clicking the square, it will automatically light up and generate an uppercase letter A, corresponding to the A button on the headset.

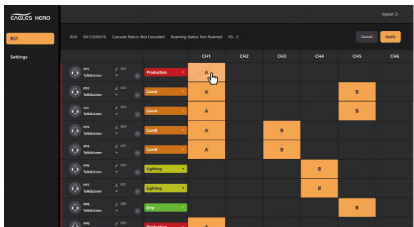



# Web Configuration

If you want to assign another group to the headset, click another gray square, and it will light up and generate an uppercase letter B, corresponding to the B button on the headset. After completing the group assignment, click **Apply**.

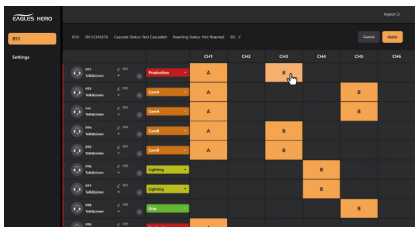

## Note:

4-Wire IN/OUT and UAC IN/OUT support a maximum of four groups, as shown in the diagram below.

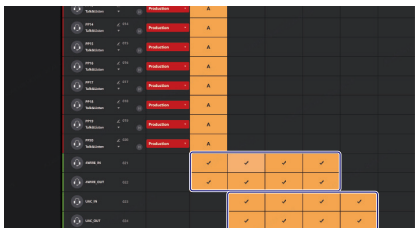

# Web Configuration

## 4.3.3 Beltpack/Headset Deletion

Click **Remove Beltpack/Headset** to access the corresponding interface, where you can select the devices that need to be deleted, and click **Apply** to confirm the deletion.

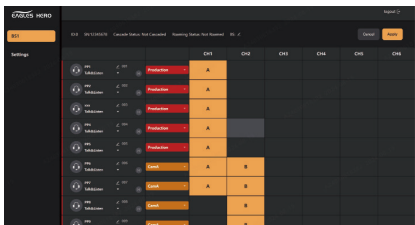

## 4.3.4 Manual Configuration

Click **Manual Configuration** to access the corresponding interface, where you can assign roles to beltpacks or headsets. The colors represent the following:

- Red: Production
- Orange: Cam A/B
- Yellow: Lighting
- Green: Grip
- White: Customized

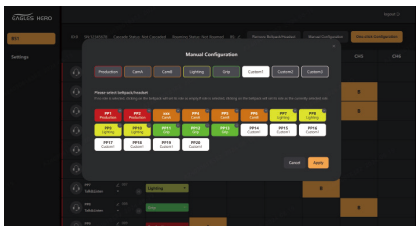

# Web Configuration

- ① Choose a role above, the selected role will be highlighted.
- ② Click the device you want to assign to this role. The selected device will be highlighted. If you want to designate the device as the head, click the H icon in the upper right corner.
- ③ Click **Apply** to save and update the settings.

## 4.3.5 One-Click Configuration

Click **One-Click Configuration** to access the corresponding interface, where you can set the number of people for each type of role based on your needs.

Click **Apply** to save and update the settings.

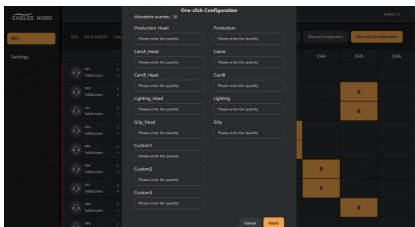

### Note:

The roles will be distributed in sequence based on the headset serial numbers. For example, if you assign two people to the role of Production Head, devices numbered 1 and 2 will be assigned as Production Head. If you assign three people to the role of Production, devices numbered 3 to 5 will be assigned as Production, and so on.

## 4.3.6 Role Management

Click **Settings** > **Role Management** to access the corresponding interface, where you can view all preset roles, their default groups and talking modes.

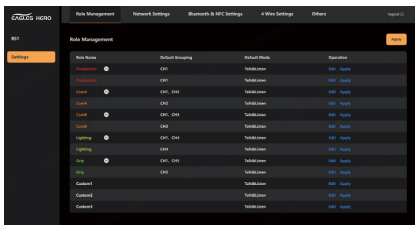

Click **Edit** to change each role's group and talking mode, and then click **Apply** to save and update the settings.

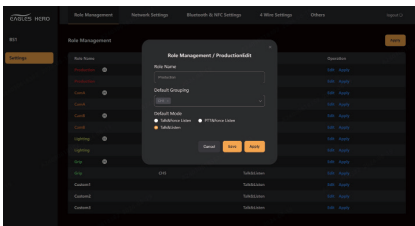

### Note:

You can restore the role management to its default settings via **Factory Reset**.

## 4.3.7 Network Settings

Click **Settings** > **Network** to access the corresponding interface, where you can choose to automatically obtain or manually set the hub's IP address. When you choose the latter, fill in the IP address, subnet mask, and gateway information, and click **Apply** to save and update the settings.

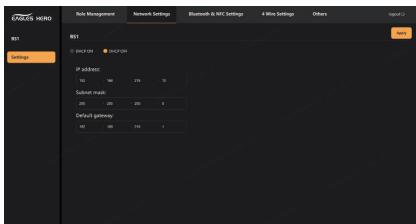

## 4.3.8 Bluetooth and NFC Settings

Click **Settings** > **Bluetooth & NFC Settings** to access the corresponding interface, where you can view the hub's Bluetooth name, Bluetooth connection status, and NFC status.

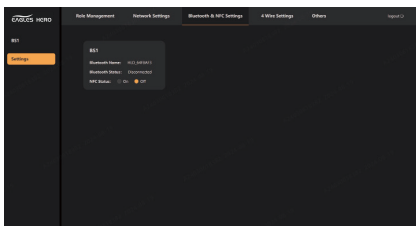

# Web Configuration

## 4.3.9 4-Wire Settings

Click **Settings** > **4-Wire Settings** to access the corresponding interface, where you can select the appropriate gain based on the input/output volume, and set the hub to Standard or Crossover. Click **Apply** to save and update the settings.

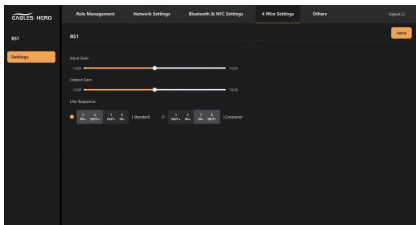

## 4.3.10 Others

Click **Settings** > **Others** to access the corresponding interface, where you can change the language, restore the hub to factory settings, modify the webpage login password, and upgrade the hub.

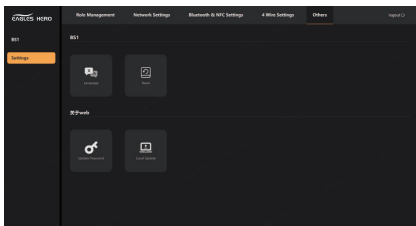

# App Configuration

## 5.1 Connecting to the Hub

- ① Download the EaglesCom app.



- ② Turn on your phone's Bluetooth and open the EaglesCom app. First-time users need to tap **Add Device** to add a new device. Other users need to tap + in the upper right corner to add a new device.

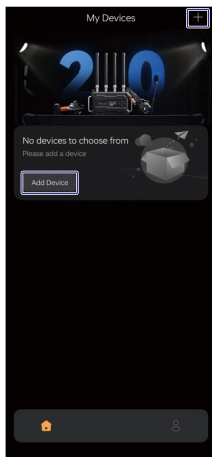

## App Configuration

- ③ Tap the device according to its Bluetooth name to establish a connection.

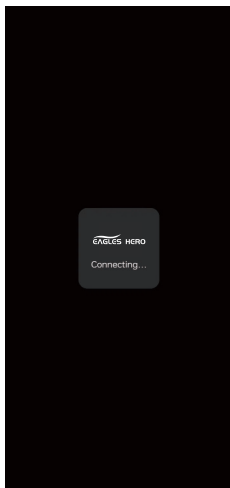
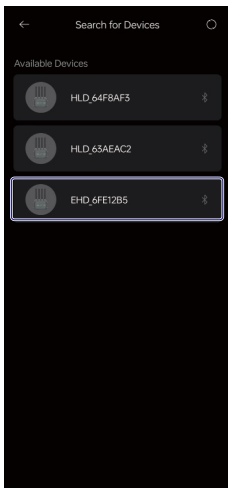



## 5.2 Home Page

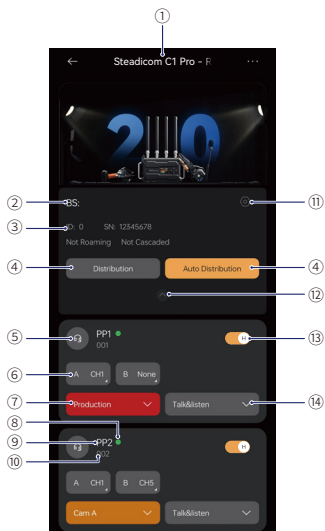

- |                                 |                       |
|---------------------------------|-----------------------|
| ① Product Name                  | ⑧ Device Status       |
| ② Hub Name                      | ⑨ Device Name         |
| ③ Hub Information               | ⑩ Device ID           |
| ④ Group Assignment              | ⑪ Hub Settings        |
| ⑤ Device Type                   | ⑫ Device List         |
| ⑥ Assigned Group for Button A/B | ⑬ Head Indicator      |
| ⑦ Device Role                   | ⑭ Device Talking Mode |

# App Configuration

## 5.3 Functions Introduction

### 5.3.1 Group Assignment

Tap the A/B button in the device card to open the group list, and select the group you want to assign it to.

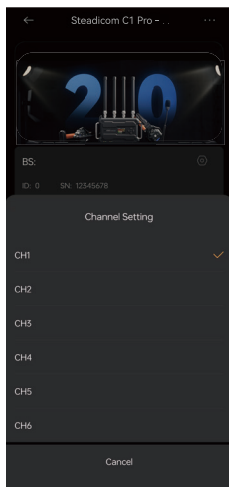
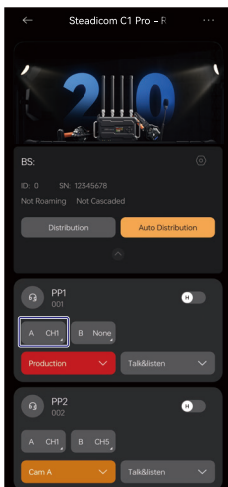

# App Configuration

## 5.3.2 Manual Configuration

Tap **Manual Configuration** to access the corresponding interface, where you can assign roles to beltpacks or headsets, including disconnected devices. The colors represent the following:

Red: Production

Orange: Cam A/B

Yellow: Lighting

Green: Grip

White: Customized

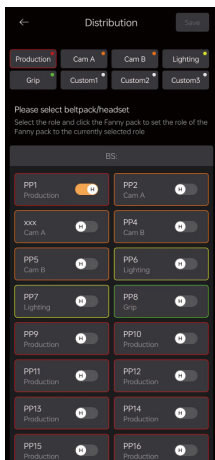

- ① Choose a role above. The selected role will be highlighted.
- ② Tap the device you want to assign to this role. The selected device will be highlighted. If you want to designate the device as the head, tap the **H** icon in the upper right corner.
- ③ Click **Save** in the upper right corner to save and update the settings.

## App Configuration

### 5.3.3 One-Click Configuration

Tap **One-Click Configuration** to access the corresponding interface, where you can set the number of people for each type of role based on your needs.

Click **Save** to save and update the settings.



The screenshot shows a mobile application interface titled "One-click Configuration". At the top left is a back arrow, and at the top right is a "Save" button. Below the title, it says "Allocatable quantity: 20". The main content is a list of roles, each with a corresponding input field for quantity. The roles and their input fields are:

Role	Input Field
Production_Head	Please enter the quantity
Production	Please enter the quantity
Cam A_Head	Please enter the quantity
Cam A	Please enter the quantity
Cam B_Head	Please enter the quantity
Cam B	Please enter the quantity
Lighting_Head	Please enter the quantity
Lighting	Please enter the quantity
Grip_Head	Please enter the quantity
Grip	Please enter the quantity
Custom1	Please enter the quantity
Custom2	Please enter the quantity
Custom3	Please enter the quantity

**Note:**

The roles will be distributed in sequence based on the headset serial numbers. For example, if you assign two people to the role of Production Head, devices numbered 1 and 2 will be assigned as Production Head. If you assign three people to the role of Production, devices numbered 3 to 5 will be assigned as Production, and so on.

## App Configuration

### 5.3.4 Beltpack/Headset Deletion

Long tap the device card to access the corresponding interface, where you can select the devices that need to be deleted, and tap the delete icon at the bottom to confirm the deletion.

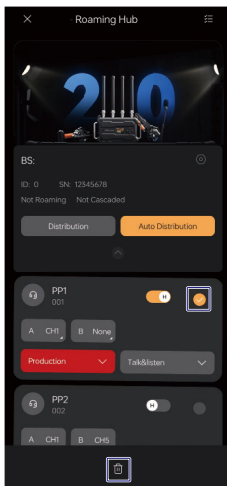

## App Configuration

### 5.3.5 Role Management

Tap the settings icon and select **Role Management** to access the corresponding interface, where you can view all preset roles, their default groups and talking modes.

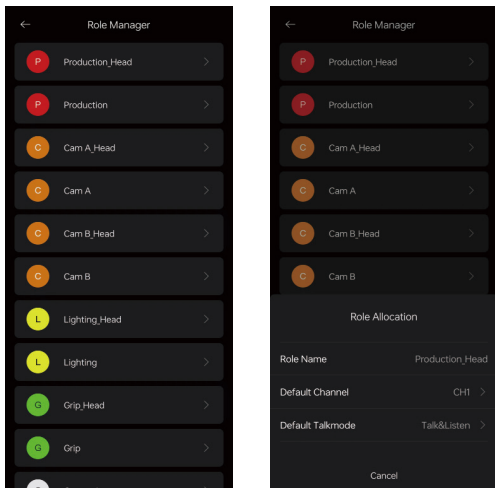

Tap a type of role to change the role's group and talking mode, and then tap **OK** to save and update the settings.

## App Configuration

### 5.3.6 Network Settings

Tap the settings icon and select **Network** to access the corresponding interface, where you can choose to automatically obtain or manually set the hub's IP address. When you choose the latter, fill in the IP address, subnet mask, and gateway information, and tap **Save** to save and update the settings.

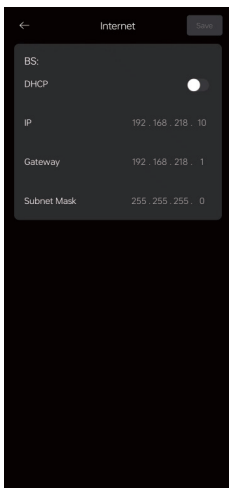

# App Configuration

## 5.3.7 4-Wire Settings

Tap the settings icon and select **4-Wire Settings** to access the corresponding interface, where you can select the appropriate gain based on the input/output volume, and set the hub to Standard or Crossover. Tap **Save** to save and update the settings.

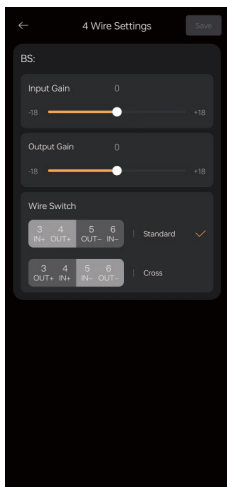



## App Configuration

### 5.3.8 Bluetooth and NFC Settings

Tap the settings icon and select **Bluetooth & NFC Settings** to access the corresponding interface, where you can view the hub's Bluetooth name, Bluetooth connection status, and NFC status.

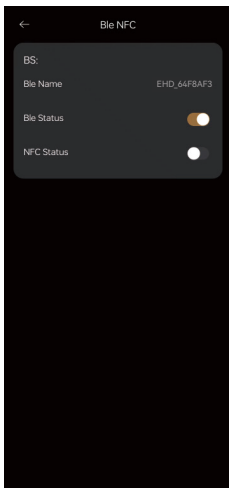

## 5.3.9 Factory Reset

Tap the settings icon and select **Factory Reset**, a pop-up window will appear indicating the hub to be reset. Tap **OK** to start the reset process.

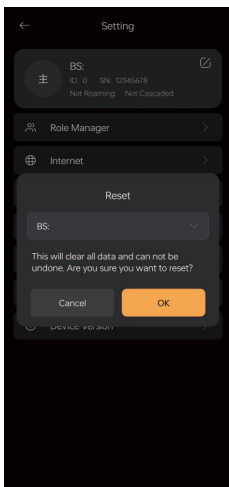

## 5.3.10 Version Information

Tap the settings icon and select **Version Info** to access the corresponding interface, where you can view the hub's SN, hardware version, and software version.

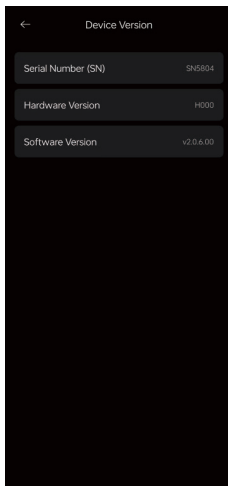

## Disclaimer

### Safety Precautions

Do not place the device near or inside heating devices (including but not limited to microwave ovens, induction cookers, electric ovens, electric heaters, pressure cookers, water heaters, and gas stoves) to prevent the battery from overheating and exploding. Use the original charger, data cables, and batteries provided with the product. Using unauthorized or incompatible chargers, data cables, or batteries may cause electric shock, fire, explosion, or other dangers.

# Disclaimer

## Support

If you encounter any problems in using the product or need any help, please contact Eagleshero Support Team via the following ways:

 Eagleshero

 eagleshero.official

 Eagleshero Official

 Eagleshero

 Eagleshero

 Eagleshero Official

 support@eagleshero.com

 www.eagleshero.com

## Statement

All copyrights belong to SHENZHEN XIANGYING TECHNOLOGY CO.,LTD. Without the written approval of SHENZHEN XIANGYING TECHNOLOGY CO.,LTD., no organization or individual may copy or reproduce part or all of any written or illustrative content and disseminate it in any form.

## Trademark Statement

All the trademarks are owned by SHENZHEN XIANGYING TECHNOLOGY CO.,LTD.

## Note:

Due to product version upgrades or other reasons, this User Manual will be updated from time to time. Unless otherwise agreed, this document is provided as a guide for use only. All representations, information, and recommendations in this document do not constitute warranties of any kind, express, or implied.

The logo features a stylized, thick black swoosh above the text. The text "EAGLES HERO" is rendered in a bold, black, sans-serif font. The letters are closely spaced, with "EAGLES" and "HERO" separated by a small gap.

**EAGLES HERO**

Manufacturer/Производитель: SHENZHEN XIANGYING TECHNOLOGY CO., LTD.

Address/Адрес: The first and second floors of Zhongyuntai Technology Industrial Plant in Tangtou Community, Shiyan Street, Bao'an District, Shenzhen, 518108, China

MADE IN CHINA/СДЕЛАНО В КИТАЕ